

POST INSTALLATION GUIDE

WoodShield posts are a non-treated pine post fully encapsulated in a recycled polyethylene (plastic) coating and generally utilize the same installation methods and fasteners as standard timber posts. They have very thick end caps to aid in mechanical installation. It is very important that to ensure maximum lifespan is achieved that some care is taken during installation.

It is strongly advised that the following guidelines are taken during installation:

NB: Ease & method of installation would depend on ground conditions.

1. For rocky or very hard ground, spiking or drilling the ground is necessary before “ramming” posts.
2. “Ripping” of the ground is perfectly acceptable for soft ground without rocks when installing the 83mm/95-100mm posts.
3. 83mm posts require a pre drilled or pre spiked hole of approx. 75mm
95/100mm posts require a pre drilled or pre spiked hole of approx. 90mm
123mm posts require a pre drilled or pre spiked hole of approx. 120mm
4. Mechanical “rammers” or vibratory post drivers are to have a flat contact plate (not domed) to ensure driving load is evenly distributed across entire end cap and shield of post
5. Cutting of post is not recommended but if required a natural timber preservative or sealant **MUST BE USED!**
6. When drilling holes in the post, the diameter of the hole must be no larger than the bolt, screw or nail diameter.
7. Most regular timber fasteners including barbed staples are acceptable. We recommend you choose a fastener that does not expose the timber.
8. The post is a non-treated timber post and therefore exposure of the timber can result in rot & insect attack.

Please do not hesitate in contacting WoodShield for any installation enquiries.

BOX ASSEMBLY

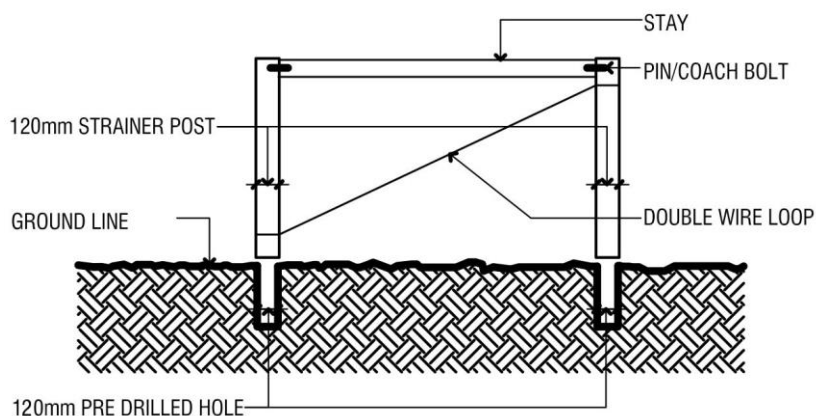

ANGLE STAY ASSEMBLY

